

REVISIONS				
REV.	DESCRIPTION	DATE	APPROVED	
A	INITIAL RELEASE	5/19/2016		
B	CHANGED SCREW HOLES TO BE BLIND; REMOVED PREVIOUS SET SCREWS AND SILICONE	5/19/2016		
C	CABLE SPEC UPDATE	11/8/2017		

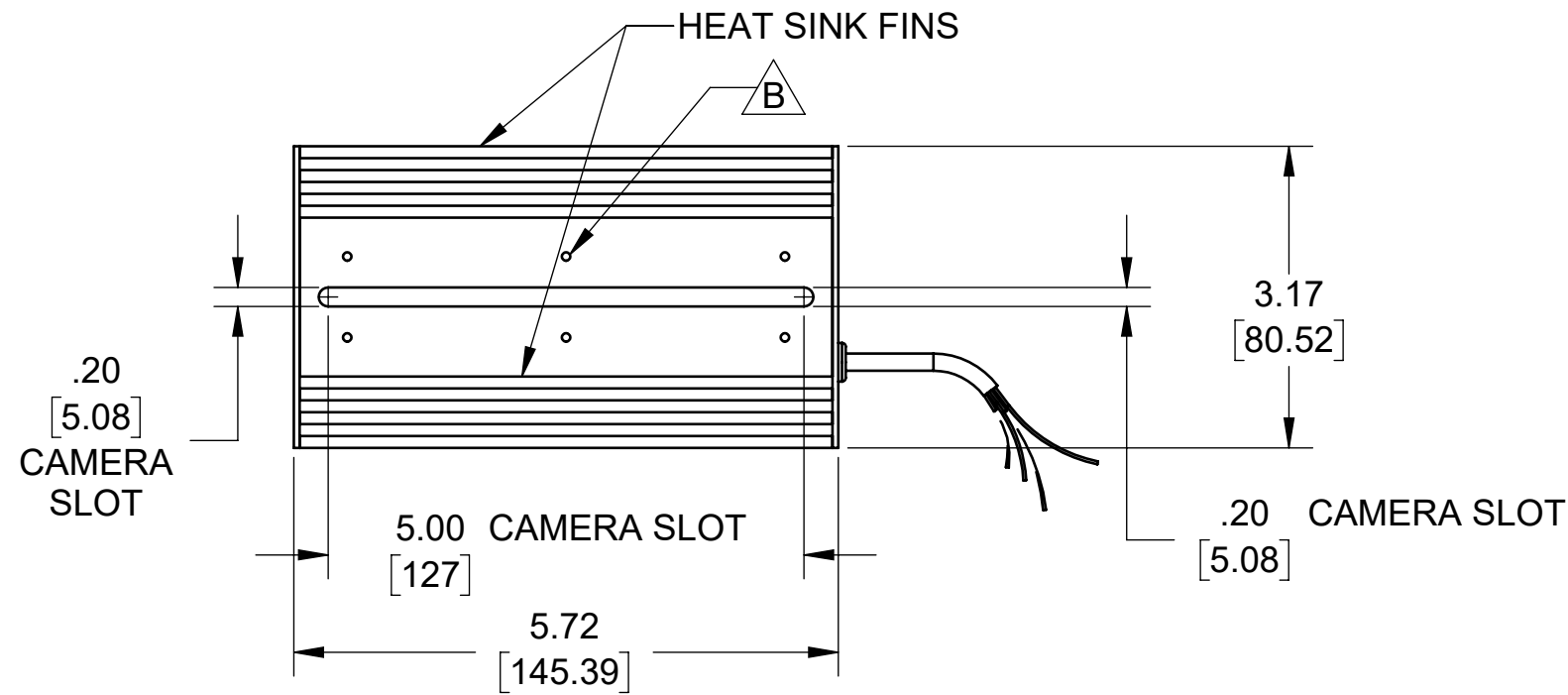

POWER CABLE  
24 AWG Stranded;  
4 conductor  
10' Cut length

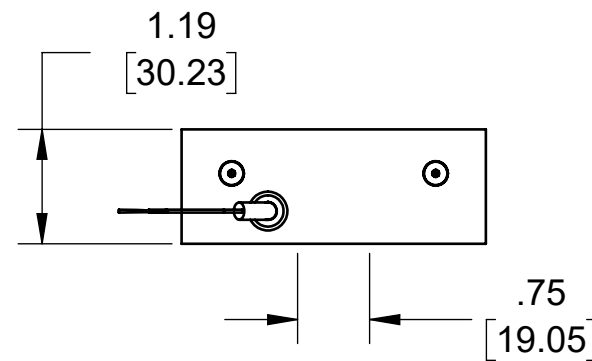
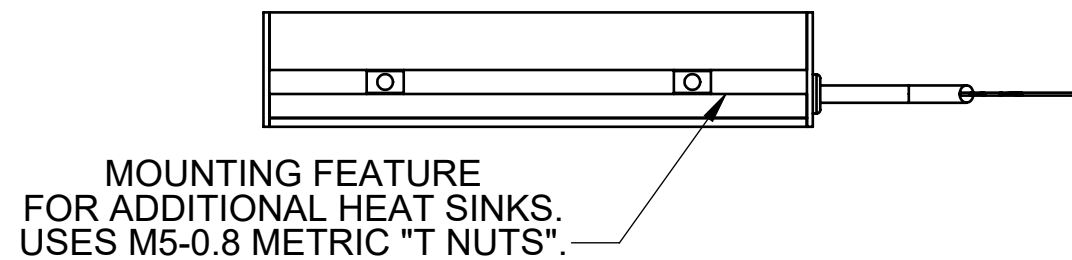
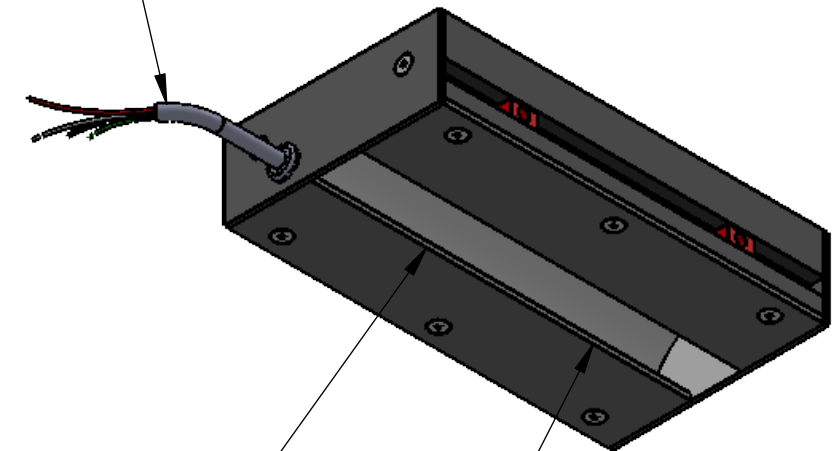

.75 LIGHT SLOT

BOTTOM VIEW

WHITE INTERNAL AREA FOR SUPERIOR LIGHT REFLECTION.

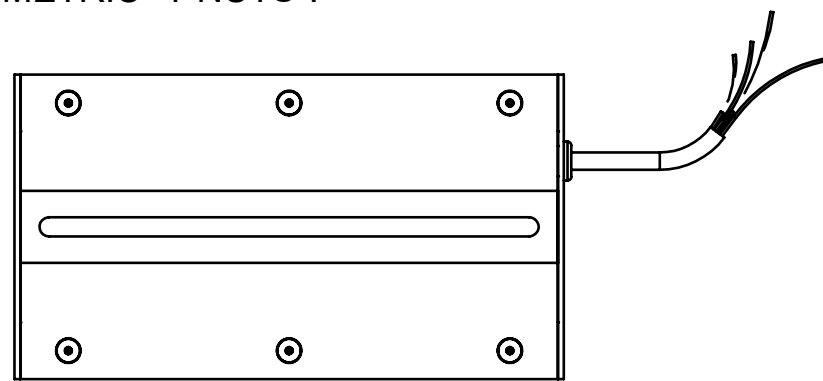

SEE SHEET 2 FOR EXPLODED VIEW AND BOM.

FINISH: BLACK ANODIZED W/ INTERIOR PAINTED WHITE - SEE SHEET 3.

Metaphase Technologies, Inc. 211 Sinclair Road, Suite 100, Bristol, PA. 19007 215-639-8699 Fax 215-639-0977



QUANTITY:	Per order
MATERIAL:	Per BOM
FINISH:	See note
TREATMENT:	N/A

TOLERANCE/FINISH UNLESS OTHERWISE SPECIFIED				
INCHES [MM]				
X	.X	.XX	.XXX	125√RMS [RA3.2um]
[±.76]	±.030 [±.25]	±.010 [±.13]	±.005	ANGLES ±1°

THIS DOCUMENT IS THE PROPERTY OF METAPHASE TECHNOLOGIES, INC. WHOM MAY LOAN IT, SUBJECT TO RETURN UPON DEMAND. IT INCLUDES CONFIDENTIAL & PROPRIETARY INFORMATION WHICH MAY NOT BE DISCLOSED TO ANY THIRD PARTY, AND/ OR USED FOR ANY PURPOSE CONTRARY TO IT'S INTENDED USE, WITHOUT THE EXPRESSED PRIOR WRITTEN CONSENT OF METAPHASE TECHNOLOGIES, INC.

TITLE  
Top Assembly; CDT206 -5" Light

USED ON  
Per customer

SIZE B	DRAWING NUMBER CDT206-1	REV C
SCALE 1:2		SHEET 1 OF 1

Approval Signature

/ /  
Date