

REVISIONS			
REV.	DESCRIPTION	DATE	APPROVED
A	INITIAL RELEASE	3/23/2018	

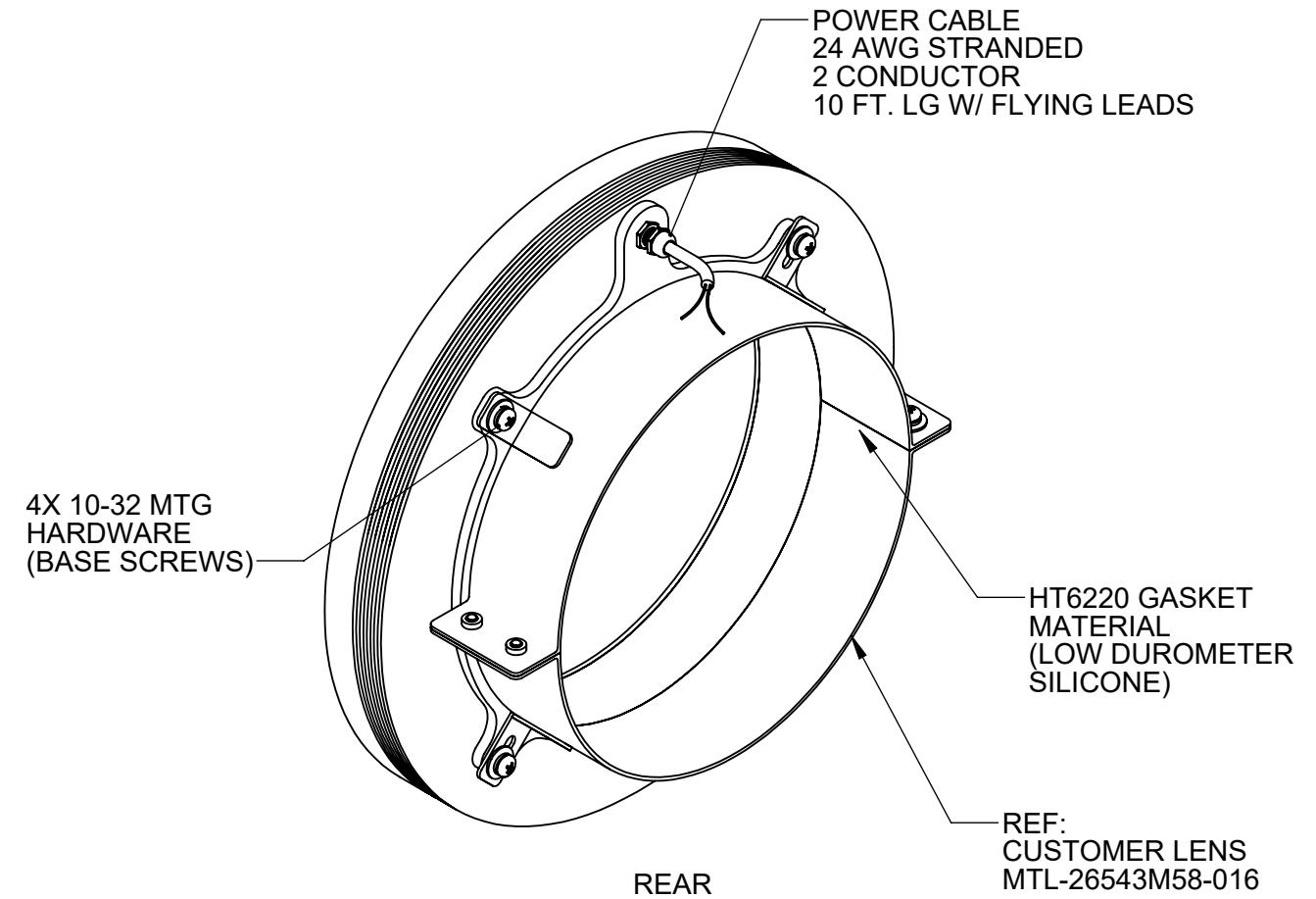

Metaphase Technologies, Inc. 211 Sinclair Road, Suite 100, Bristol, PA. 19007 215-639-8699 Fax 215-639-0977

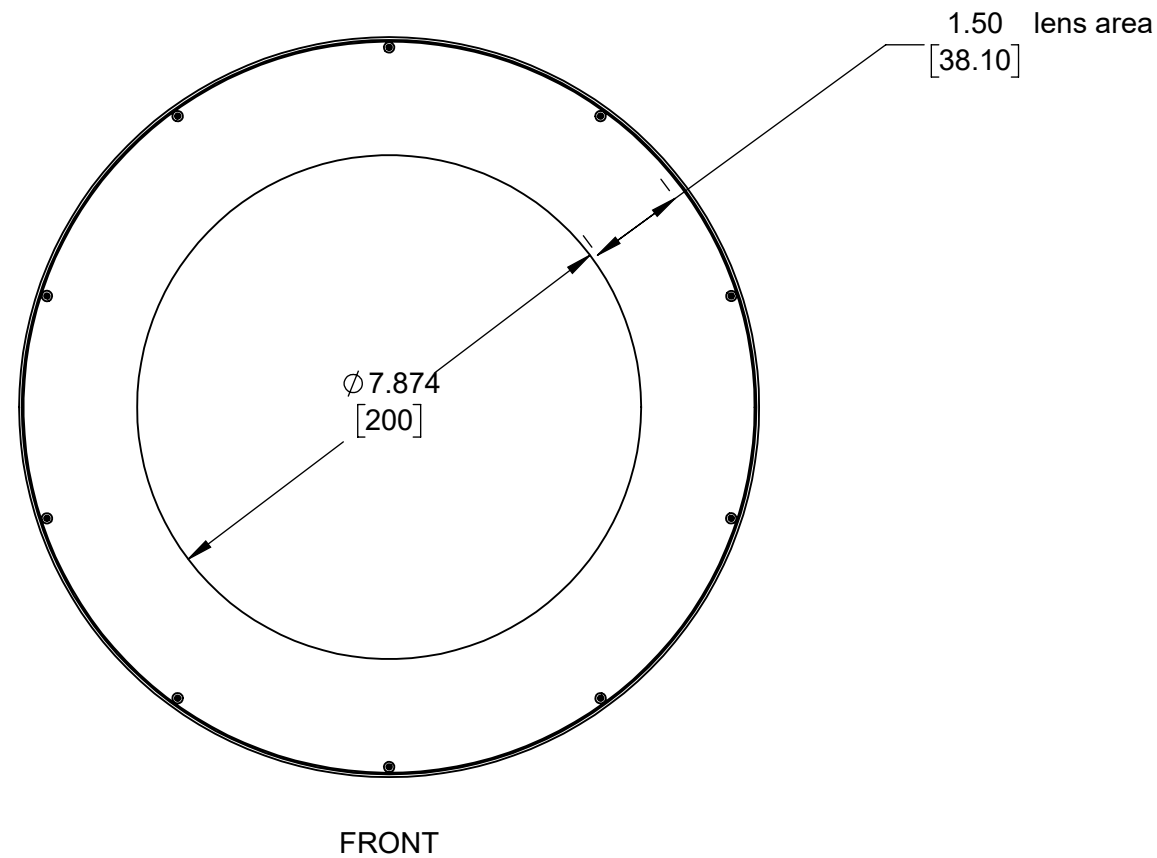
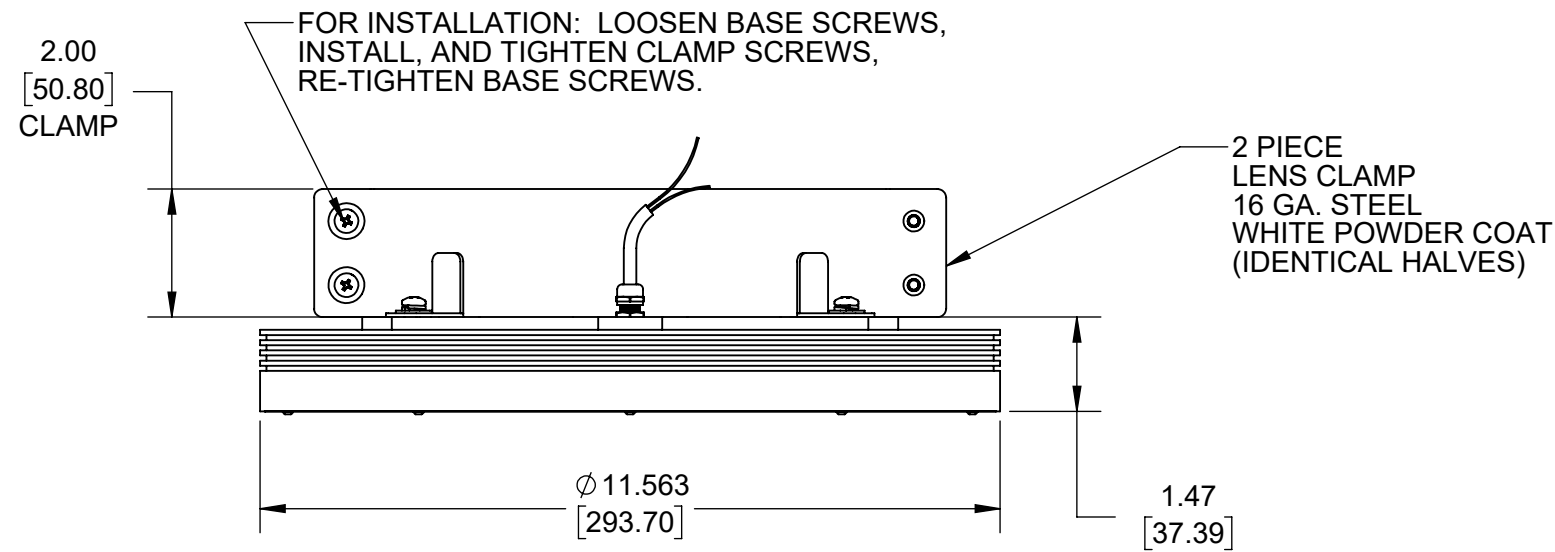

QUANTITY:	Per order
MATERIAL:	Per BOM
FINISH:	See note
TREATMENT:	N/A

TOLERANCE / FINISH UNLESS OTHERWISE SPECIFIED				
INCHES [MM]				125√RMS [RA3.2um]
X	.X	.XX	.XXX	
[±.76]	±.030 [±.25]	±.010 [±.13]	±.005	ANGLES ±1°

THIS DOCUMENT IS THE PROPERTY OF METAPHASE TECHNOLOGIES, INC. WHOM MAY LOAN IT, SUBJECT TO RETURN UPON DEMAND. IT INCLUDES CONFIDENTIAL & PROPRIETARY INFORMATION WHICH MAY NOT BE DISCLOSED TO ANY THIRD PARTY, AND/ OR USED FOR ANY PURPOSE CONTRARY TO IT'S INTENDED USE, WITHOUT THE EXPRESSED PRIOR WRITTEN CONSENT OF METAPHASE TECHNOLOGIES, INC.

TITLE
Top Assy.; 200mm Ring Light

USED ON
Per customer

SIZE B	DRAWING NUMBER MB-RL20005-1	REV A
SCALE 1:4		SHEET 1 OF 1

Approval Signature

/ /
Date